

POWERBEAD

P B 8 5

P B 2 0 0

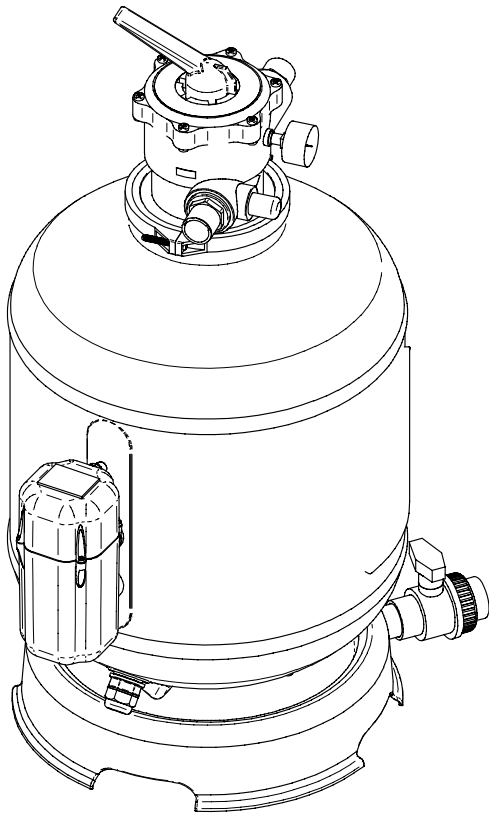

PB 85

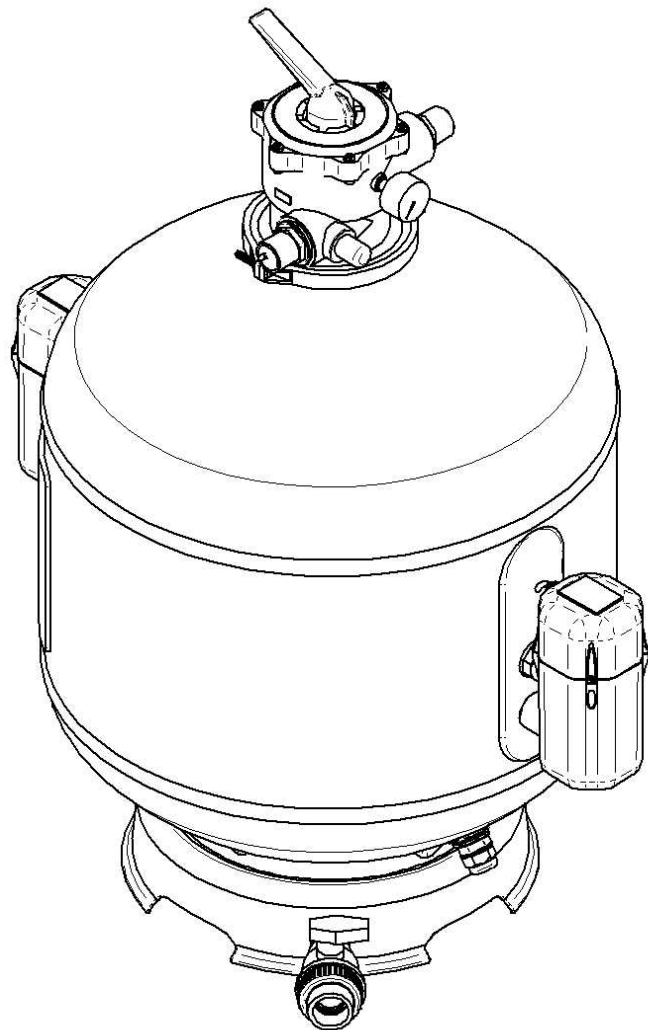

PB 200

ELECR
ENGINEERING

**INSTALLATION & OPERATING
INSTRUCTION MANUAL**

DO NOT DISCARD KEEP FOR FUTURE REFERENCE

FILTER DESCRIPTION

- 1-Multifunction valve
- 2-Locking clamp
- 3-O-Ring seal
- 4-Tank
- 5-Base
- 6-Pipe with diffuser
- 7-Internal jet system
- 8-Agitation Pump
- 9-Drainage tap
- 10-Drainage valve
- 11-Beads (Not shown in the exploded diagram)
- 12-Accessories bag (Not shown in the exploded diagram)

The filter works by allowing pond water to pass through the beads producing both biological and mechanical filtration of the water.

Mechanical Filtration

Three stage filtration

- *Sedimentation:* The heaviest particles that enter the tank settle to the bottom and will be flushed out when the drainage valve (10) is opened.
- *Mechanical Filtration:* The water passes through the filtration media where medium particles are trapped (suspended) by the media (beads).
- *Bacterial Filtration:* The finest particles become 'stuck' to the beads to enable biological filtration to take place (See the paragraph "Biological Filtration")

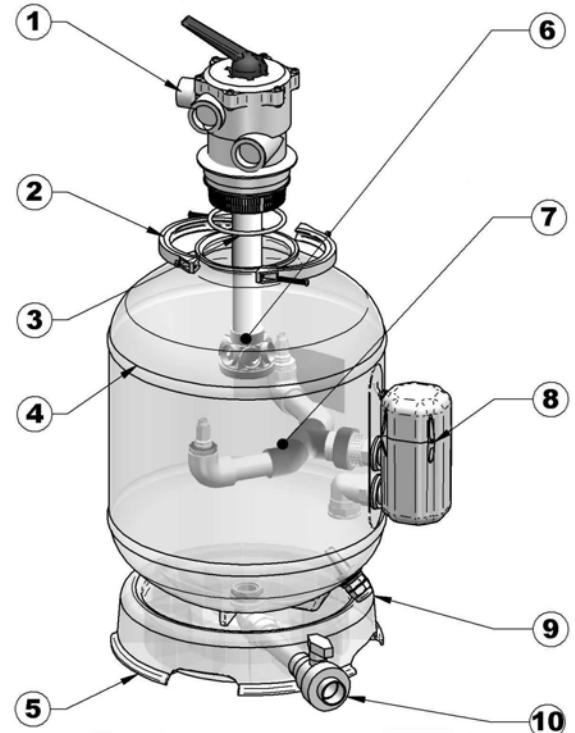

FIG.1

Attention! The biological / bacterial filtration process will start to take place 4 to 6 weeks after the filter is initially installed. (See the paragraph Biological Filtration).

Attention! The mechanical filtration of the product cannot hold or remove micro weeds / algae. To obtain crystal clear water we strongly advise using a suitable UV treatment.

It is advised to backwash the filter once a week or when a reduction of water flow is noticed.

Biological Filtration

The filter eliminates toxins created by the plants and animals' metabolism by making use of the Nitrogen cycle.

The Nitrogen cycle is a natural process resulting in dissolved toxins being rendered harmless

The break up of organic material in the water (fish excrement, leaves, weeds, etc.) especially in an acidic environment (with a PH level greater than 7.5), produces ammonium and ammonia that are both extremely toxic to fish.

The large filter media surface and the simultaneous presence of ammonium, ammonia and oxygen allow the production of a beneficial bacterial community inside the filter. There are two types of bacteria that flourish in this environment: the Nitrosomonas and the Necrobacter. The bacteria Nitrosomonas convert the ammonium and the ammonia into nitrites, after this the bacterial Necrobacter changes these nitrites into nitrates, substances that are much less toxic for fish. As these two transformation processes consume oxygen, the continuous operation of the filter is essential.

NOTE: it will take at least 4-6 weeks for the filter to become biologically active. Accelerators are readily available from Koi / Aquatic stores and their use can dramatically reduce the initial formation time. It is essential during initial start up to monitor the level of ammonia and nitrites in the pond. If the ammonia and nitrite values become excessive it is advisable to change the pond water immediately.

Attention! To have an efficient biological function the water alkaline level must be no greater than 80mg/l.

Attention! The Nitrosomonas and the Necrobacter bacteria live only when oxygen is present. If the water stops flowing through the filter even for a few hours they will die. Therefore the filter **MUST** be pump feed 24 hours a day (The side mount agitator pump will not assist in oxygenating the water).

Attention! To enable the bacteria to grow it is advised not to backwash for 3-4 weeks after the initial installation. Only backwash before if a drastic reduction in water flow is noticed.

After the initial 3-4 weeks it is suggested to backwash the filter once a week, or each time a large reduction in water flow is noticed.

Filter innovations

Your Powerbead filter differs from other bead filters due to the patented innovations that we have introduced. The first is the internal diffuser (6) and the second is the new agitation & cleaning method of the beads (8). These innovations lead to:

- **Increased Safety:**

The new-patented system to wash the beads uses an agitation pump (8) and a system of internal jets (7) that pump high velocity water against the dirty beads agitating them violently. The pump used to wash the beads has an electrical insulation rating of IPX6 your filter it is therefore much safer compared to the traditional systems with air blowers.

- **Increased Functionality:** With the same mechanical-biological filtration features as the current systems available on the market today the Powerbead filter is easier to operate & maintain. The innovative shape of the new diffuser reduces the maintenance on the filter.

Important Information

This filtration system has been designed to work with fresh water ponds.

Place the filter beside the pond in an area protected from sunlight.

This filter has been designed for domestic use.

The filter cannot hold microscopic weeds or algae. To eliminate them a suitable UV-C treatment should be used.

- Maximum water temperature: 35°C

- Minimum water temperature: 4°C

- Alkaline water level: ≥ 80mg/l

Model	Maximum Pond Capacity		Bead Quantity	Indicative Flow Rate	Filter Dimensions
	Heavy Stock	Light Stock			
PB85	13,600-litres / 3000-gallons	22,700-litres / 5000-gallons	13-kg	6000 - 10000-litres per hour	Ø 47x98cm
PB200	22,700-litres / 5000-gallons	40,900-litres / 9000-gallons	26-kg	8000-15000-litres per hour	Ø 65x110cm

Attention! The backwash frequency will depend on the quantity of fish and the feed rate. It is good practice to clean the filter every time a large reduction in water flow is noticed.

Pump to be coupled with the filter

Maximum prevalence: 1bar = 10meters

Flow rate: The pump flow rate must be capable of recirculating the entire volume of the pond at least 10-12 times a day (24 hour period).

WARNINGS AND SAFETY RULES

Read and keep in a safe place.

The filter has been designed to work with domestic fresh water ponds.

Do not submerge the filter in the water.

Never use pumps with a prevalence over 10m.

Make sure that your electric system is in accordance with the international regulations in force.

Make sure that the product is compatible with the features of your electric system.

The agitation pump cable must be connected to the electric supply through a 30mA RCD.

Never pull the electric cable.

The filter cable of the cleaning system cannot be replaced. If the cable is damaged the product must be scrapped.

Before handling the filter or placing hands in the water, disconnect the electrical supply to all pond equipment.

The system must not operate for longer than the period indicated within these instructions.

Never remove, for any reasons, the protective case of the agitation pump. A specialized technician must carry out the maintenance of this part.

FILTER INSTALLATION

Positioning the filter

The filter must not be submersed in the pond, please see the diagram Fig. 3.
 The drainage tap and drainage valve (9 & 10) must be easily accessible.
 The filter must be positioned on a level plane (base) that must be able to hold the weight of the filter when full of water. (120Kg PB85 – 220 Kg PB200)
 Once installed and filled with water, the filter cannot be moved.

Adding the media / beads

Make sure that the drainage tap and drainage valve (9 & 10) are closed.
 Fill the filter body with water until it's ¾ full.

Before adding the media:

Check that the internal jets (7) are positioned as shown in Fig.11 if they have moved the original position must be restored using the union that secures the pipe work connected to the jets (inside the filter body). Unscrewing the internal ring releases the jet system and it can then be taken out.
 Pour the filter media (Beads) into the tank - Fig.5
 Ensure the internal jets are still positioned correctly as shown in Fig.11

Multifunction valve assemble

Carefully clean the neck of the tank - Fig.6
 Make sure that the O-Ring (3) is well positioned on the multifunction valve (Point 1 of Fig.7)
 Insert the pipe with the diffuser (6) into the multifunction valve (1) - Fig.8.
 Assemble the valve (1) on the tank, fixing it with the supplied locking clamp (2) – Fig.9
 Screw the hoesetails into the correct ports (labelled POND & PUMP) using the O-Rings, supplied in the accessories bag.

Attaching the Pressure Gauge

Remove the white bung from the multiport valve.
 Apply some Teflon (PTFE) tape (supplied) around the manometer thread to guarantee a correct seal. Do not use an excessive amount of tape, or you will expand the thread and cause an inaccurate reading, only wrap the thread twice with the tape.
 Screw the manometer into the multiport valve using a correctly sized key/spanner – do not screw in by the plastic casing of the pressure gauge or you will damage the gauge. Fig.10

Pipe connections

Fix the connecting pipes with the hose clips (jubilee clips) following the example shown at the Fig. 12 where: D = Pond E = Pump F = Filter A-B-C-H = Pipes G = Drain / Waste.
 Connect the pipe (A-Fig.12) that connects the OUT from the pump (E-Fig.12) to the valve hoesetail (1) of the filter (F-Fig.12) marked with the sticker "PUMP".
 Connect the pipe (B-Fig.12) that goes from the pond to the valve hose tail (1) marked with the sticker "POND".
 Close / bung the exit valve (1) marked with the sticker "WASTE" screwing the correct cap/bung, supplied in the accessories bag.
 In Fig.12 the exit "WASTE" is not symbolized as shut, but connected to the drain through pipe (H-Fig.12). See the function "Draining".
 To drain the dirt far from the filter, a pipe (C-Fig.12) must be connected to the drainage valve (10) through a threaded hoesetail 1¼" easily available in the market.

NOW YOUR FILTER IS READY TO WORK.

FILTER USE

Read carefully the before starting/using the filter.

Filter starting

- 1) Set the multifunction valve to position 1. **Attention!! The valve selector must only be moved when the pond pump is off. To move it, push down on the handle and turn towards the desired position.**
- 2) Check that the drainage valve (10) and the drainage tap (9) are closed.
- 3) The cleaning system (8) must be switched off.
- 4) Switch on the pond pump (PUMP)
- 5) Now your filter can start working.

The pumped water enters the tank through the valve, exits the diffuser pipe (6) and travels up through the beads before returning to the pond.

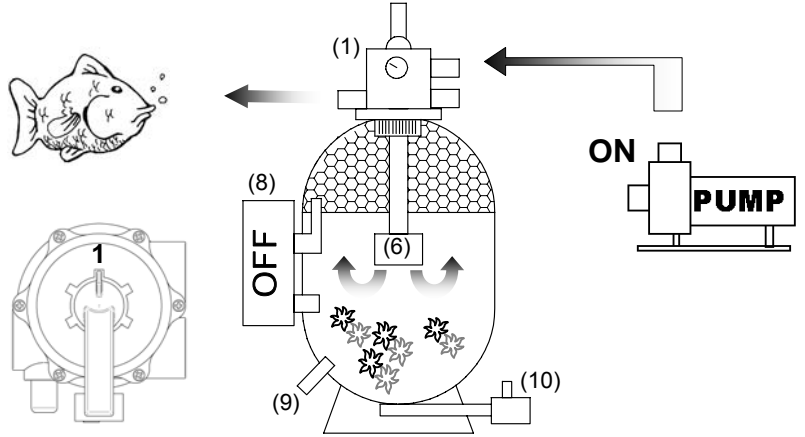

Filter cleaning

- 1) Whilst the filter is working (i.e. with the pond pump on) open the drainage valve (10) this will release the large / heavy deposited dirt. Leave the valve open until the dirty water becomes clear. (Normally after 4-6 seconds) Then close the tap again.

Attention! It is normal that during the deposit draining some beads run out together with the dirt.

- 2) Switch off the pond pump. (PUMP)
- 3) Set the multifunction valve to position 5 CLOSED.
- 4) Turn the agitation pump on (8), for around 3-5 minutes; this will violently agitate the beads setting the suspended dirt free.

Read carefully the warnings and the safety rules before starting the agitation pump.

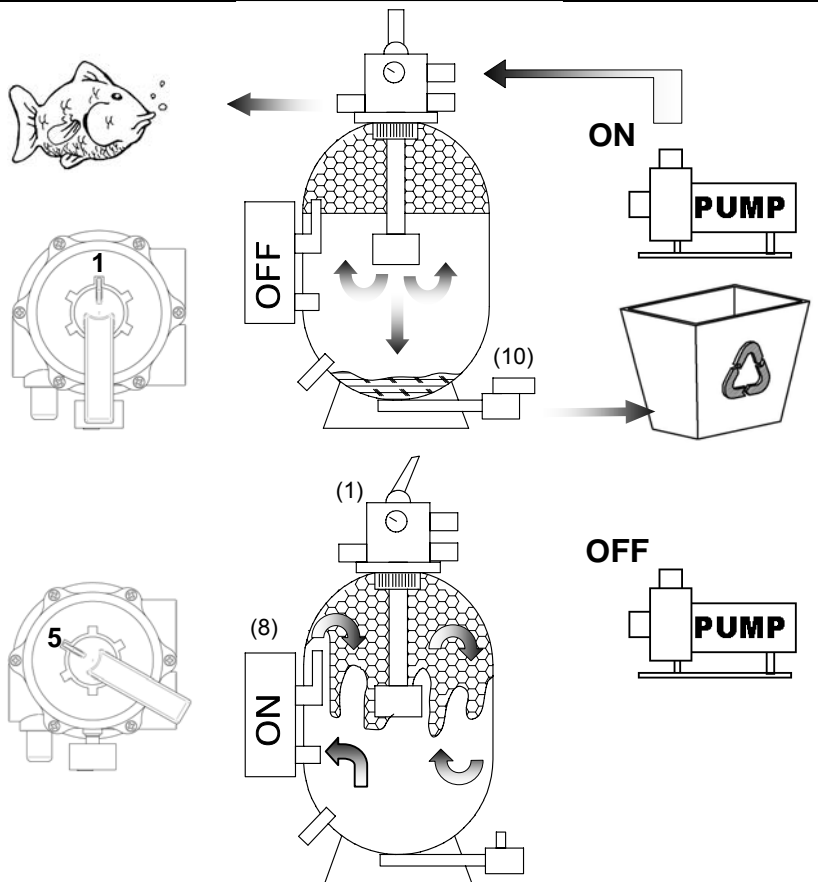

- 5) Turn the agitation pump off (8).
- 6) To fully clean the beads a backwash is necessary. Set the multifunction valve to position 2 BACKWASH.
- 7) Open the drainage valve (10).
- 8) Turn on the pond pump (PUMP). The water will flow from the top of the filter to the bottom through the beads, carrying the dirt and discharging it through the drainage valve (10).
Leave the pump switched on until the water coming out from the drainage valve starts to become clear. It is advised not to leave it for more than 1-2 minutes at a time.

This forced water exchange guarantees the pond the right levels of iron, calcium, phosphates, and other element values that fish and bacteria regularly absorb from the water.

During the cleaning phase some beads can run out from the drainage pipe (C-Fig.12).

The use of a hand net is advised to avoid their waste into the environment.

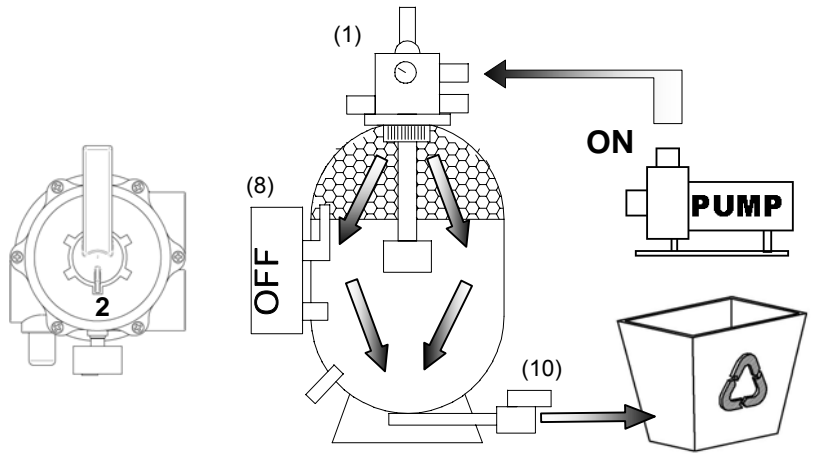

Restore of the "Filtering" function

- 1) Switch the pond pump off. (PUMP)
- 2) Close the drainage valve (10).
- 3) Reposition the multifunction valve back to position 1 FILTER.
- 4) Switch the pond pump on. (PUMP)
- 5) The filter is now operating.

Attention!! After cleaning the filter it is possible that some beads may have entered the pond.

Attention!! After restarting the filter, water returning to the pond may appear slightly dirty for a few seconds.

A weekly backwash process is suggested.

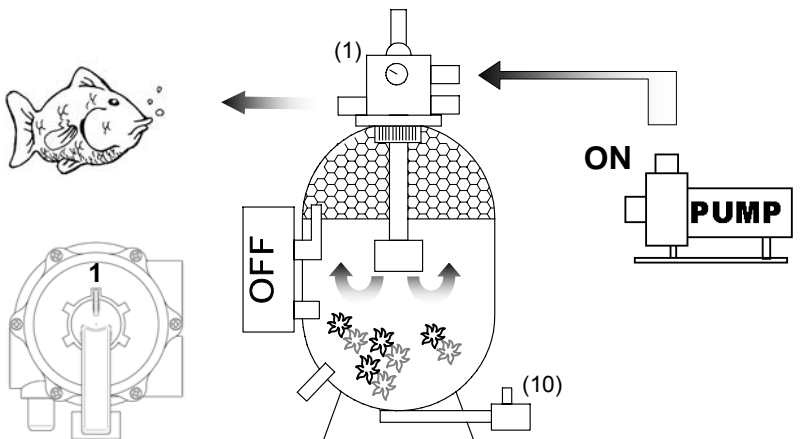

Special functions

Winter storage

- 1) Make sure that the pond pump is switched off.
- 2) Move the multifunction valve to position 0 WINTER.
- 3) Drain the water by opening drainage tap (9); the operation will be faster if drainage valve (10) is also used. Ensure that beads do not run out.
- 4) Washing the cleaning system. (See "Maintenance" paragraph)
- 5) Protect the filter from frost.

Damage caused by frost is not covered under warranty.

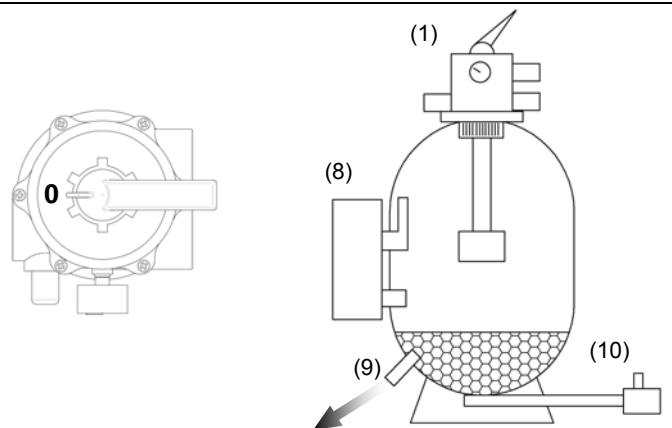

Recirculate

This function allows the recirculation of the pond water without it travelling through the filter itself. It can be used when chemical treatments are being used in the pond. See "Medication of the pond" paragraph.

- 1) Make sure the pond pump is switched off.
- 2) Set the multifunction port to position 4 RECIRCULATE
- 3) Switch the pond pump on.

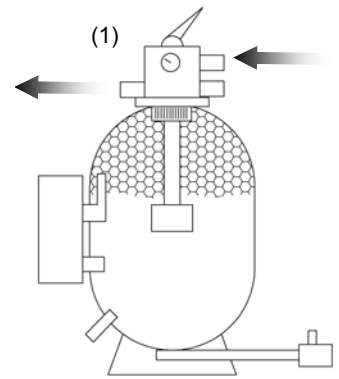
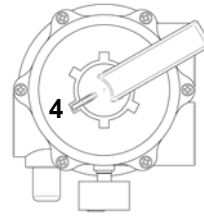

Draining

The function "Draining" allows you to drain the water from the pond without it passing through the filter. Make sure the pond pump is switched off.

- 1) Unscrew the bung/cap in the multifunction valve WASTE.
- 2) Screw the hosetail with the special O-Ring fixing the pipe that goes to the drain. H-Fig.12 with the clamp.
- 3) Set the multifunction valve to position 3 WASTE
- 4) Switch the pond pump on.

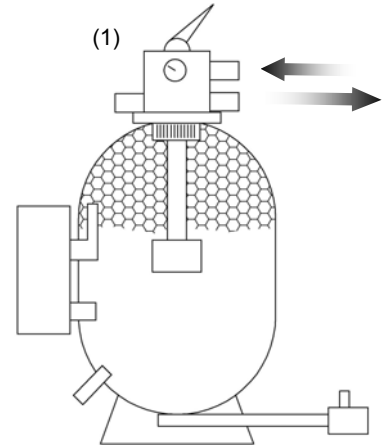
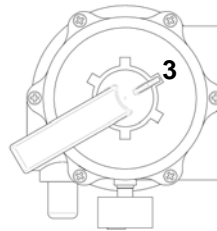

MEDICATION OF THE POND

If you need to add medication to the pond it is recommended that the "Recirculate" function be used. This function allows the circulation of the pond water without it passing through the filter body, avoiding any damage to the bacteria that live inside the filter. Before starting the "Recirculate" function always operate as follow:

- 1) Thoroughly clean/backwash the beads. (See the "Filter cleaning" paragraph)
- 2) Set the multifunction valve to position 1 FILTER
- 3) Unscrew the transparent cap (1- Fig.9) on the multifunction valve.
- 4) Drain the water unscrewing the drainage tap (9). You can speed up the operation by opening the drainage valve (10). During this process you must ensure you do not allow beads to also drain away.
- 5) Close the drainage tap (9) and close the drainage valve (10).
- 6) Reattach the transparent cap (1- Fig.9) to the multifunction valve (1).
- 7) Set the multifunction valve to position 4 RECIRCULATE.

With the presence of oxygen inside the filter the bacteria can live for many days. Now the filter is ready to carry out the "Re-circulate" function.

MAINTENANCE

FIGURE - IMAGES - FIGURE - FIGURE N

The filter does not need any special maintenance however it is good practice to open the filter at least once a year to:

- 1) Verify that the carter valve (Fig. 8.1) is not blocked.
- 2) Verify that the diffuser is not blocked.
- 3) Verify the status of the filter media. The beads should be clean and should not stick together.
- 4) Verify the drainage tap and valve status. If needed wash them with warm water.
- 5) Verify that the jets and the cleaning system still work. Wash the pipes if needed.

To wash any part of the filter it is advised to use warm water.

Attention! Do not use solvents.

INTERNAL JETS

For winter storage we advise that the internal jet system is cleaned. Unscrew the clamp (inside the filter body) in an anticlockwise direction, take the jets out of the tank and wash them with warm water. When reassembling the jets ensure they are placed exactly as shown in Fig. 11.

Attention! Never use solvents.

PROBLEMS	POSSIBLE CAUSES	SOLUTIONS
1. Beads entering the pond	Incorrect filter assembly.	Make sure the Powerbead installation has been correctly followed.
2. Poor water flow from the filter exit even after backwashing.	The agitation pump does not work.	<ul style="list-style-type: none"> • Verify that the pump is correctly connected to the electric supply. • Verify that the pump works.
	The internal jets are blocked	Open the filter and check how the internal jets look. If they are blocked they need to be cleaned.
	The beads are stuck together	<ul style="list-style-type: none"> • Open the filter and separate the compressed beads. • Clean the filter more often. • Reduce the feed rate.
3. Dangerous level of toxic substances after 4-6 weeks of operation	First thing: Immediately change a majority of the pond water.	
	Verify that the filter has been correctly assembled.	Follow the instructions indicated in the paragraph filter installation.
	Fish stock is too high	It may be necessary to add another filter.
	Decay of organic material	Clean the pond properly.
	Filter system not suitable to the pond.	See paragraphs "Application limits and field" and "Pump to be connected".
4. The pond water becomes dirty.	Feed rate is too high	Reduce the feed rate
	Remember, to obtain clear water a sterilisation system based on an algacide UV-C system is needed.	
	The backwash has not been correctly followed.	Read carefully the filter cleaning instructions and carry out this operation weekly.
	Filtration system not suitable to the pond.	See paragraphs "Application limits and field" and "Pump to be connected".

Please contact your dealer for any other advise

FIGURE - IMAGES - FIGURE - FIGUREN

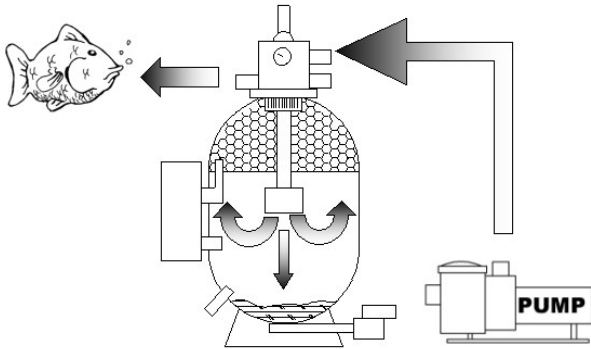

FIG.2

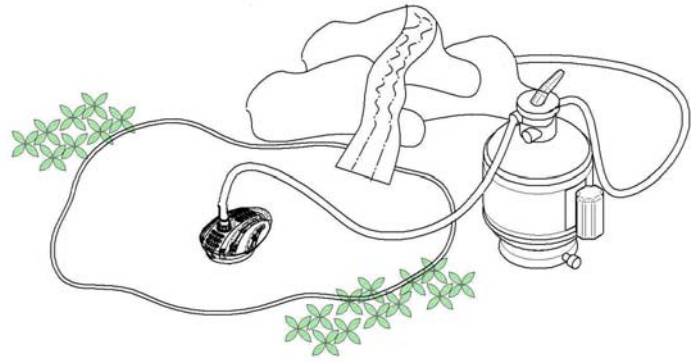

FIG.3

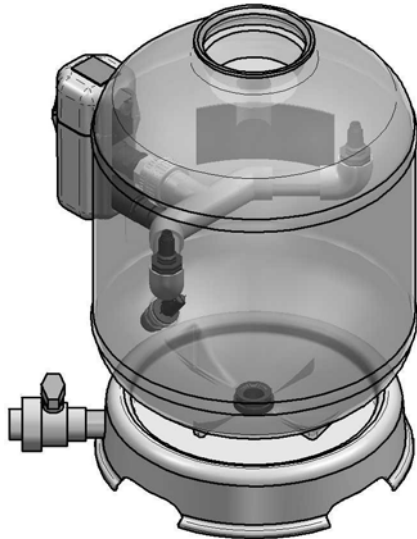

FIG.4

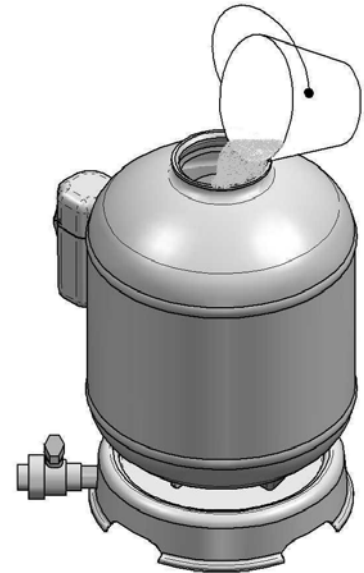

FIG.5

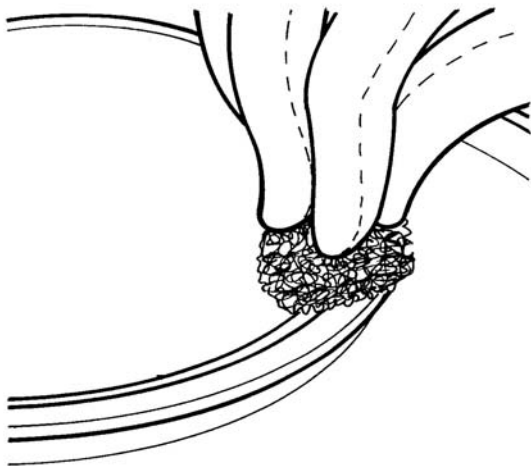

FIG.6

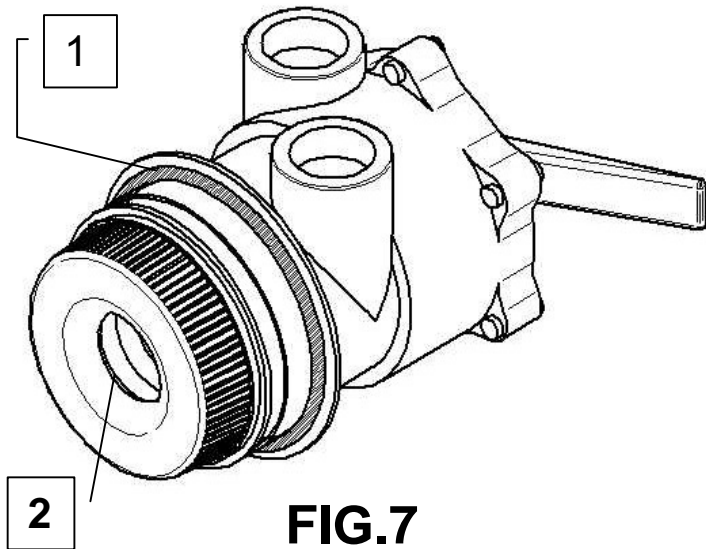

FIG.7

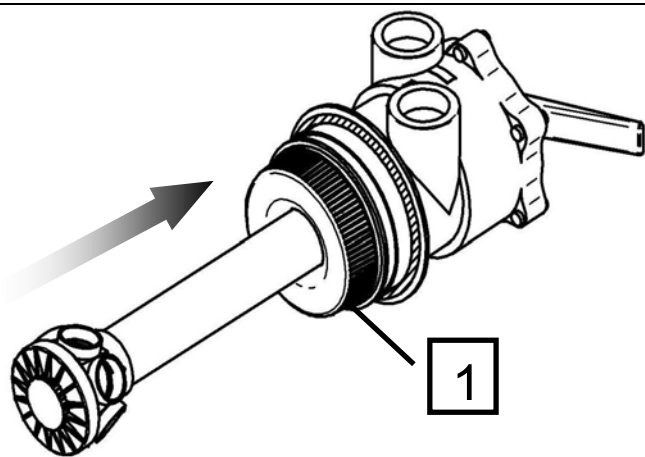

FIG. 8

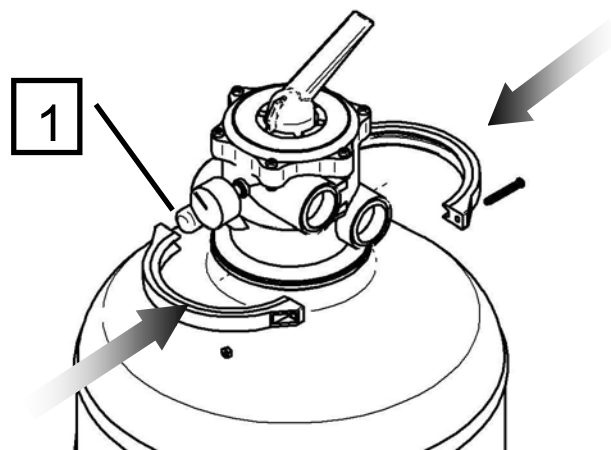

FIG. 9

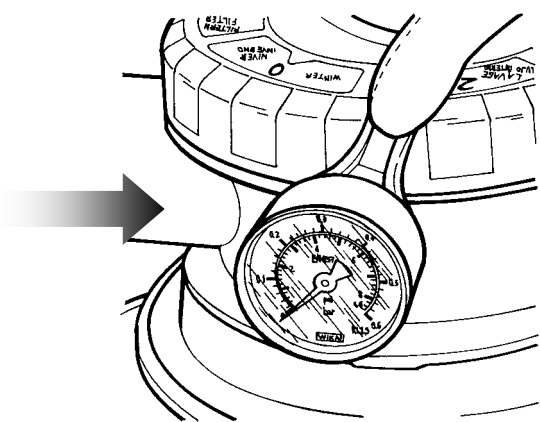

FIG. 10

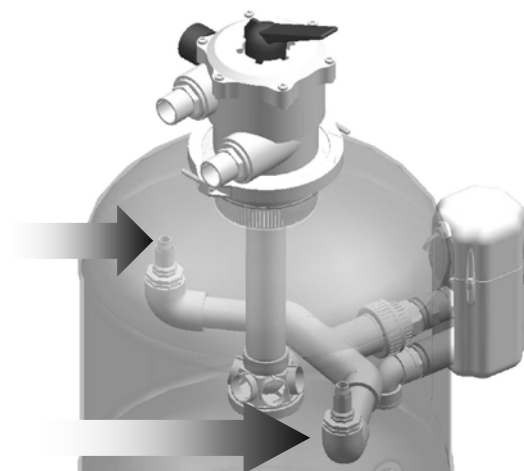

FIG. 11

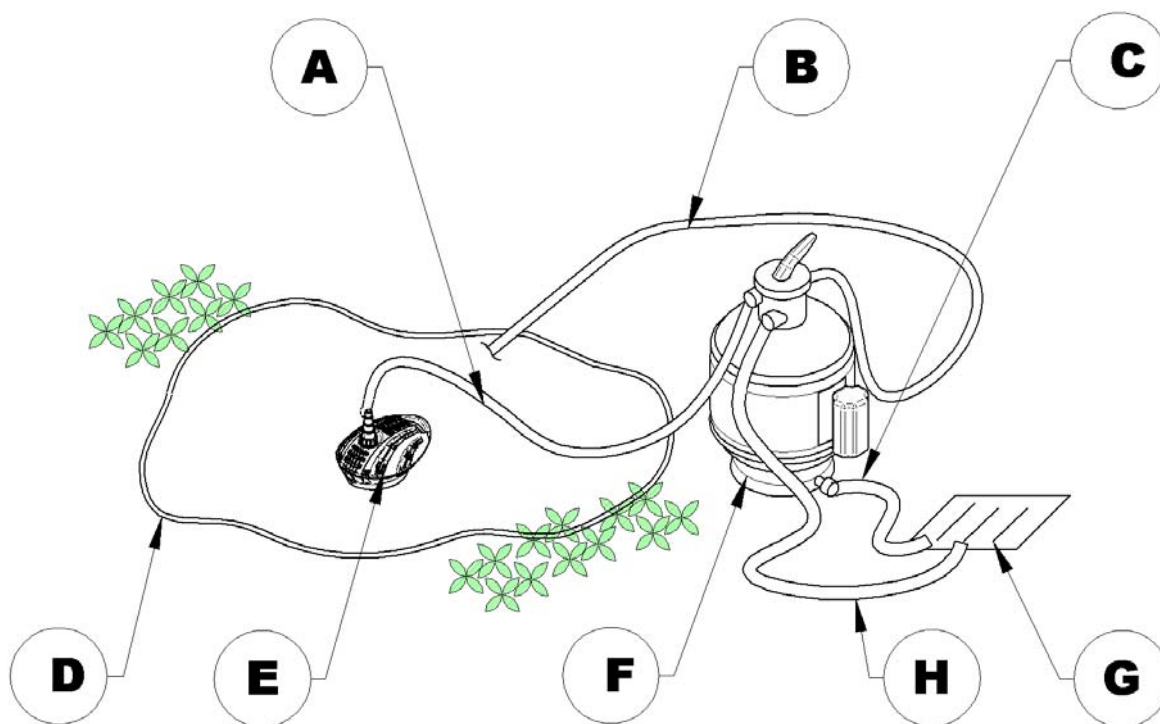
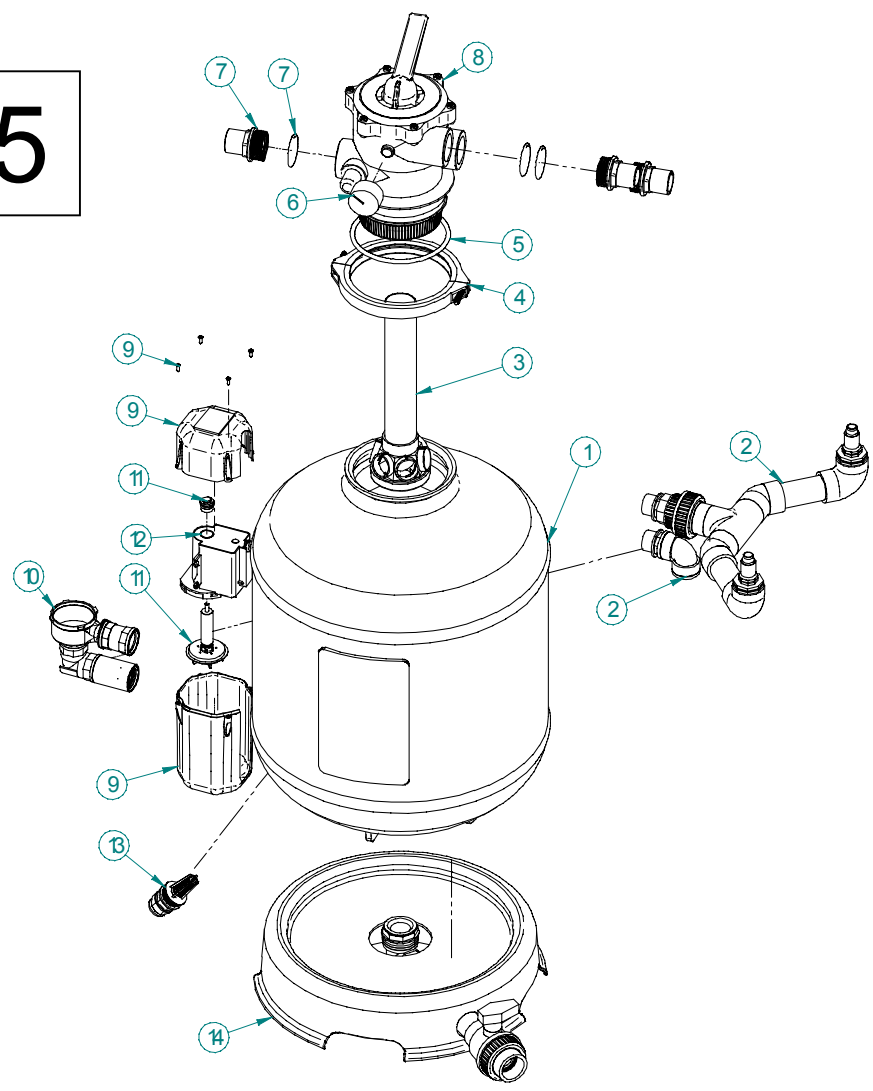

FIG. 12

PB85



#	Code	Description
1	XP107N	Tank 85lt Powerbead
2	XP110N	Complete Set Inner Jets
3	XP113S	Complete Diffuser + Tube
4	XR903S	Clamp Set
5	XR380S	O-ring For Valve
6	XR902N20	Manometer
7	XR900S38	Hosetail 38mm + O-ring (3x)
8	XP115N	Valve 6 Way Powerbead
9	XP117N	Carter + Screw Shake Pump
10	XP119N	Volute 14 Powerbead
11	XR200N	Rotor/Impeller + Bearing
12	XP121N	Motor Shake Pump
13	XR920S	Bottom Drain
14	XP124N	Base + Sludge Valve

PB200

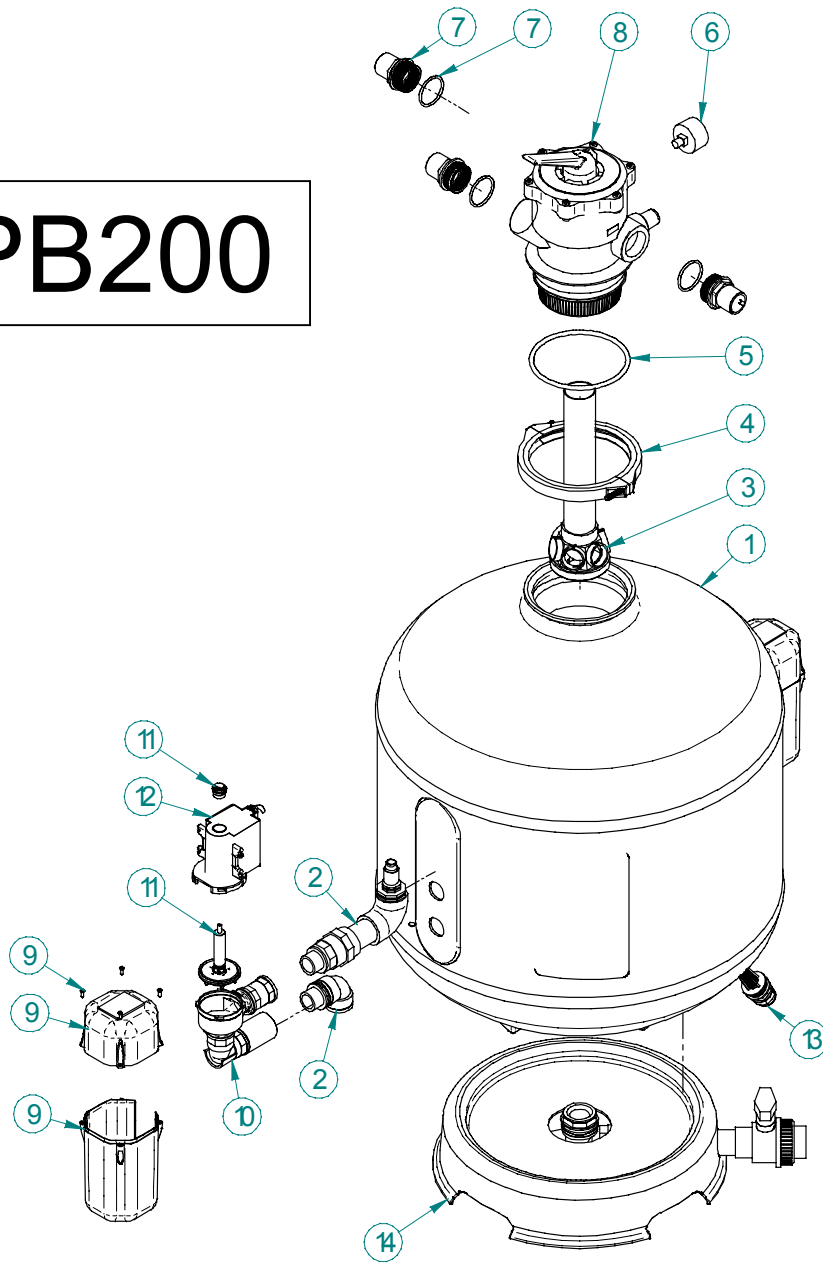

#	Code	Description
1	XP106N	Tank 200lt Powerbead
2	XP111N	Complete Set Inner Jets 200lt
3	XP114S	Complete Diffuser
4	XR903S	Clamp Set+Screw
5	XR380S	O-ring For Valve
6	XR902N20	Manometer
7	XR900S38	Hosetail 38mm + O-ring (3x)
8	XP115N	Valve 6 Way Powerbead
9	XP117N	Carter + Screw Shake Pump
10	XP119N	Volute 14 Powerbead
11	XR200N	Rotor/Impeller + Bearing
12	XP121N	Motor Shake Pump
13	XR920S	Bottom Drain
14	XP124N	Base + Sludge Valve